

Thick Film Precision Resistors Networks

Custom-designed elements available

The various types of multiple METOXFILM circuits feature the same excellent performance characteristic of other EBG metal oxide devices. Careful attention is devoted to the individual customer's design so as to comply not only with the requirements of resistance value, tolerance and TCR, but also power handling and stability during life, even under adverse conditions.

Most of EBG's multiple component designs are computer-generated and thus avoid any possibility of "hot spot" long-term deterioration. In addition, trimming is accomplished in digital step fashion by computer-controlled lasers.

EBG owns several US- and European-manufactured lasers, which enable us to meet a wide range of requirements.

While EBG has developed a standard product line of voltage divider models as shown here, we are also well-suited to develop an exact custom-designed circuit for you, employing high precision, high stability, low TCR and wide resistance range coverage without neglecting your important requirements.

We encourage you to consult our Applications Engineering Department about your special requirements.

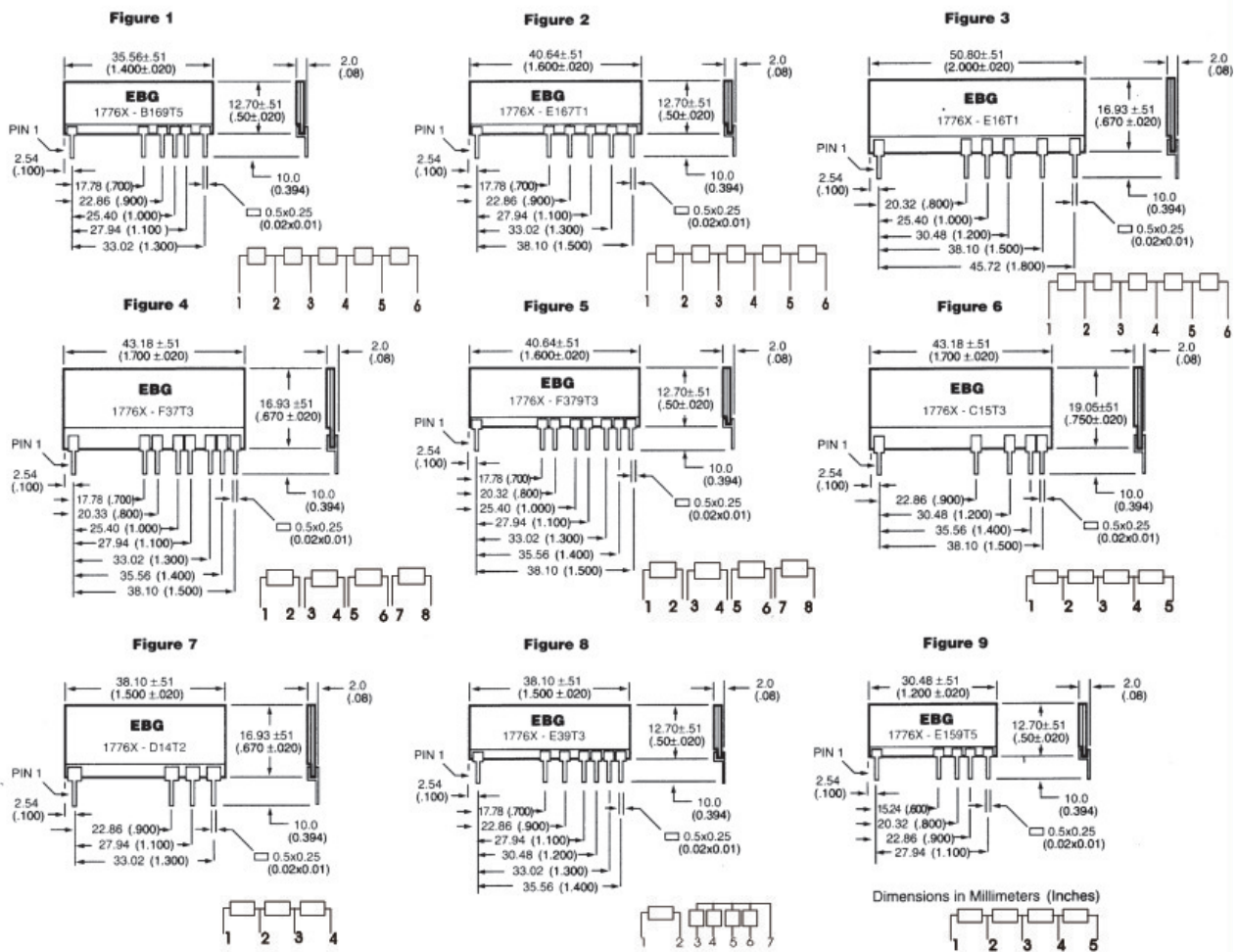

The above spec. sheet features our standard products. For further options, please contact our local EBG representative or contact us directly. For updated information, please visit our website!