

Series HXP 200, SOT-227

200 W Power Resistor in the "ISOTOP" power device

A Miba Group Company

1/2

Due to our Non-Inductive design, the HXP series is ideally suited for high-frequency and pulse-loading applications. Through direct mounting on a heat sink, significant cost advantage can be realized. Main applications are: variable speed drives, power supplies, control devices, telecommunications, robotics, motor controls and other switching devices.

Features

- multiple resistors in 1 package
- Non-Inductive design
- ROHS compliant
- Materials in accordance with UL 94 V-0

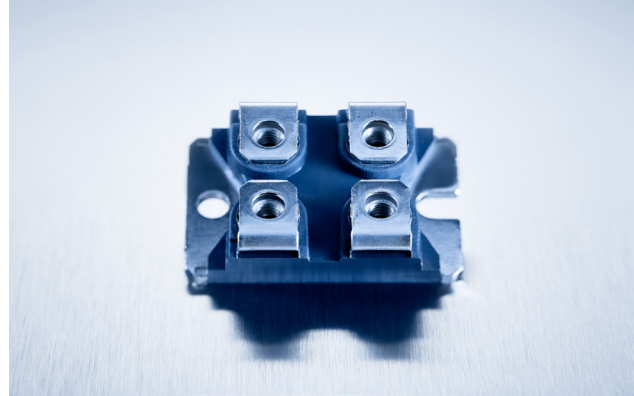

Technical Specifications

Resistance value	0.1 Ω ≤ 1 MΩ
Resistance tolerance	±1 % to ±10 %
Temperature coefficient	> 1R: ±250 ppm/°C (at +85°C ref. to +25°C) lower TCR on special request for limited ohmic values
Power rating	up to 200 W at 85°C bottom case temperature (see configurations)
Short time overload	1.25x rated power at 85°C bottom case temperature for 10 sec., ΔR = 0.4% max. (for conf. 1, 2 and 3)
Maximum working voltage	500 V (up to 1,000 V on special request = "S"-version)
Partial discharge	up to 2,000 Vrms / 80pC (Tests only on special request)
Voltage proof	dielectric strength up to 4,000 V DC against ground
Insulation resistance	> 10 GΩ at 1,000 V DC
Isolation voltage between R1 & R2 & R3	500 V (1,000 V on special request)
Protection class	acc. to IEC 950/CSA22.2 950/M-89 and EN 60950.88:2
Comparative Tracking Index (CTI)	standard > 200 V (> 500 V on special request = "H"-version)
Heat resistance to cooling plate	Rth < 0.35 K/W
Capacitance/mass	45 pF (typical), measuring frequency 10 kHz
Serial inductivity	HXP-1 typical 40 nH, measuring frequency 10 kHz
Working temperature range	-55°C to +155°C
Mounting - torque for base plate (static)	1.3 Nm to 1.5 Nm M4 screws
Mounting - torque for contacts (static)	1.1 Nm to 1.3 Nm M4 screws, screw-in depth max. 5 mm
Weight	~26 g

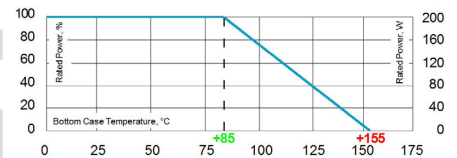

Derating (thermal resist.) HXP-200:
2.86 W/K (0.35 K/W) (for conf. 1, 2 and 3)

Best results can be reached by using a thermal transfer compound with a heat conductivity of at least 1 W/mK. The flatness of the cooling plate must be better than 0.05 mm overall. Surface roughness should not exceed 6.4 μm.

How to make an order

HXP-Configuration_Ohmic Value_Tolerance

For example:
HXP-1 1R 10% or HXP-4 2x50K 5%

Example for higher working voltage or CTI
HXP-4-S 2x40R 10% or HXPH-2 75K 5%

Configurations (P / package)

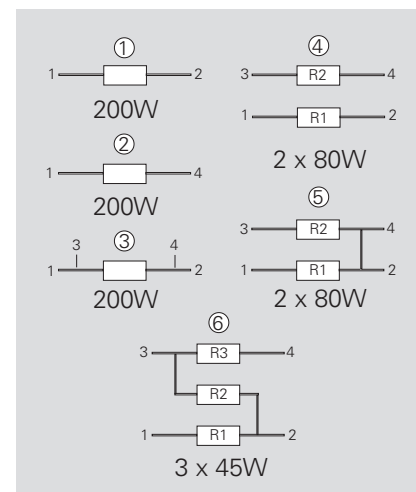

Version 5: ohmic value between contact 2 and 4 = 3mΩ

Dimensions in mm [inches]

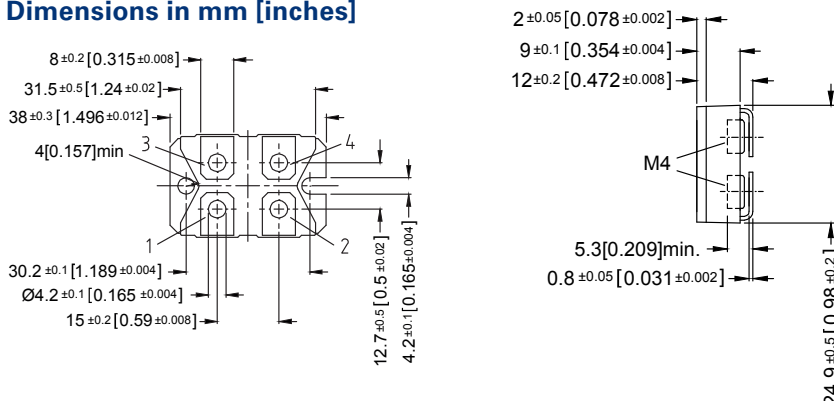

The above spec. sheet features our standard products. For further options please contact our local EBG representative or contact us directly.

Series HXP 200, SOT-227



Pulse Energy Curve (typical rating for HXP 200)

Note: These energy values are reference values → depending on ohmic value e.g. 1 Ω to 10 Ω and used resistive paste, a variation in max. energy load capability is possible

Test procedure

Every test resistor was mounted with thermal compound (0.9 W/mK) on a water cooled heatsink

- Constant inlet water temperature: +50°C
- The test time of each tested resistor: 10min.
- Break time between two pulses: 1sec.
- To determine good / defect parts the ohmic value was measured before and after tests: a change of tolerance of more than 0.1% means defect

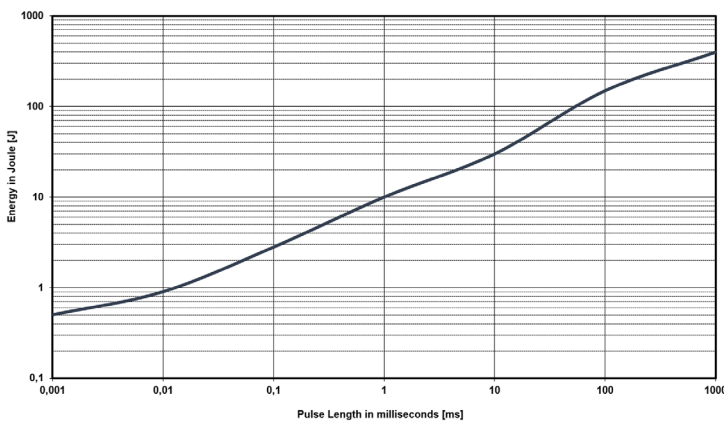

Description of Pulse Energy Curve

- Shape of pulse = e-function
- Time between two pulses = 1 second
- Pulse length = time constant of 1 tau (1 means ... tau = 1ms)

Example

At 1 ms tau the HXP 200 with e.g. 1 Ω to 10 Ω can withstand an energy level of about 10 J, when the pulse pause time is ≥ 1s

At a symmetrical frequency > 1 kHz at pulse length ≥ 10 μsec. the maximum applied pulse energy for HXP 200 is a result out of the nominal power 200 W divided by the operating frequency (at 85°C bottom case) (E = 200 W / F)

Pulse Power Curve (typical rating for HXP 200)

The power curve shows the max. possible power which can be applied for a certain duration. Referring to the same test procedure as described above.

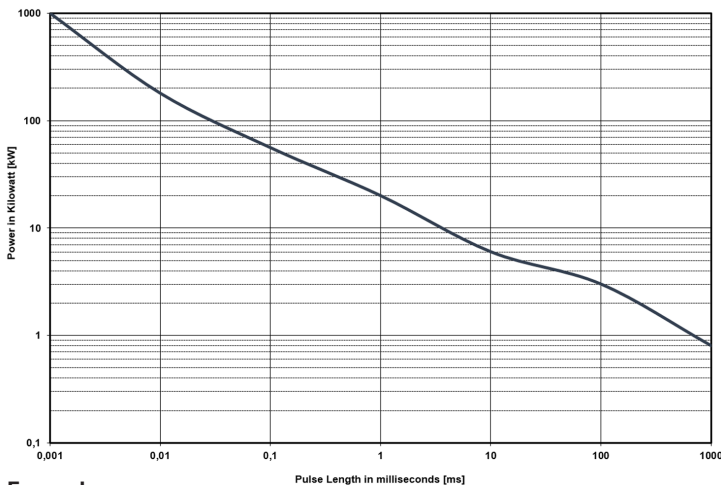

Description of Pulse Power Curve

- Shape of pulse = e-function
- Time between two pulses = 1 second
- Pulse length = time constant of 1 tau (1 means ... tau = 1ms)

Example

For the time-constant of 1 ms you can apply about 20 kW max. ($P_p = 2 \cdot E / T$) →, if the time between two such peaks is ≥ 1s

The above spec. sheet features our standard products. For further options please contact our local EBG representative or contact us directly.