



# Series HXP 200, SOT-227

200 W Power Resistor in the "ISOTOP" power device



Due to our Non-Inductive design, the HXP series is ideally suited for high-frequency and pulse-loading applications. Through direct mounting on a heat sink, significant cost advantage can be realized. Main applications are: variable speed drives, power supplies, control devices, telecommunications, robotics, motor controls and other switching devices.

## Features

- multiple resistors in 1 package
- Non-Inductive design
- ROHS compliant
- Materials in accordance with UL 94 V-0
- Resistor is also available with UL certification (ask for details)
- Resistor is also available with preapplied PCM (Phase Change Material) (ask for details)

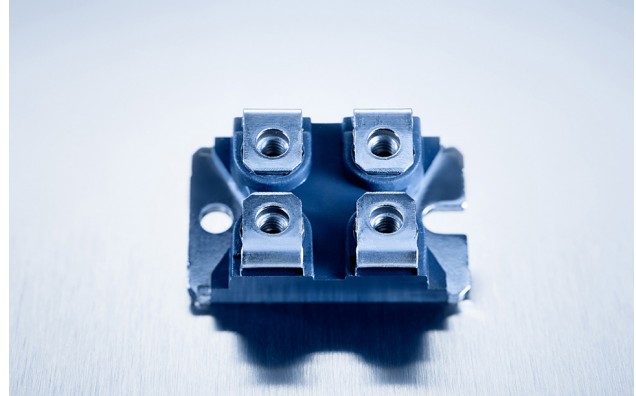

## Technical Specifications

<b>Resistance value</b>	0.1 Ω ≤ 1 MΩ
<b>Resistance tolerance</b>	±1 % to ±10 %
<b>Temperature coefficient</b>	> 1R: ±250 ppm/°C (at +85°C ref. to +25°C) lower TCR on special request for limited ohmic values
<b>Power rating</b>	up to 200 W at 85°C bottom case temperature (see configurations)
<b>Short time overload</b>	1.25x rated power at 85°C bottom case temperature for 10 sec., ΔR = 0.4% max. (for conf. 1, 2 and 3)
<b>Maximum working voltage</b>	500 V (up to 1,000 V on special request = "S"-version)
<b>Partial discharge</b>	up to 2,000 Vrms / 80pC (Tests only on special request)
<b>Voltage proof</b>	dielectric strength up to 4,000 V DC against ground
<b>Insulation resistance</b>	> 10 GΩ at 1,000 V DC
<b>Isolation voltage between R1 &amp; R2 &amp; R3</b>	500 V DC (1,000 V DC on special request)
<b>Protection class</b>	acc. to IEC 950/CSA22.2 950/M-89 and EN 60950.88:2
<b>Comparative Tracking Index (CTI)</b>	standard > 200 V (> 500 V on special request = "H"-version)
<b>Heat resistance to cooling plate</b>	Rth < 0.35 K/W
<b>Capacitance/mass</b>	45 pF (typical), measuring frequency 10 kHz
<b>Serial inductivity</b>	HXP-1 typical 40 nH, measuring frequency 10 kHz
<b>Working temperature range</b>	-55°C to +155°C
<b>Mounting - torque for base plate (static)</b>	1.3 Nm to 1.5 Nm M4 screws
<b>Mounting - torque for contacts (static)</b>	1.1 Nm to 1.3 Nm M4 screws, screw-in depth max. 5 mm
<b>Weight</b>	~26 g

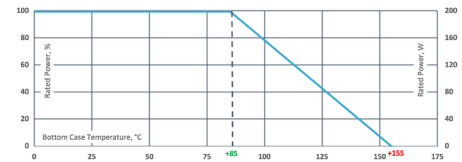

Derating (thermal resist.) HXP-200:  
2.86 W/K (0.35 KW) (for conf. 1, 2 and 3)

Best results can be reached by using a thermal transfer compound with a heat conductivity of at least 1 W/mK. The flatness of the cooling plate must be better than 0.05 mm overall. Surface roughness should not exceed 6.4 μm.

## How to make a request

HXP-Configuration\_Ohmic Value\_Tolerance

For example:  
HXP-1 1R 10% or HXP-4 2x50K 5%

Example for higher working voltage or CTI  
HXP-4-S 2x40R 10% or HXPH-2 75K 5%

## Configurations (P / package)

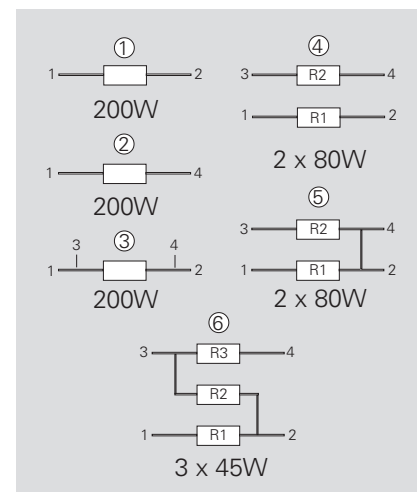

Version 5: ohmic value between contact 2 and 4 approx. 3mΩ

## Dimensions in mm [inches]

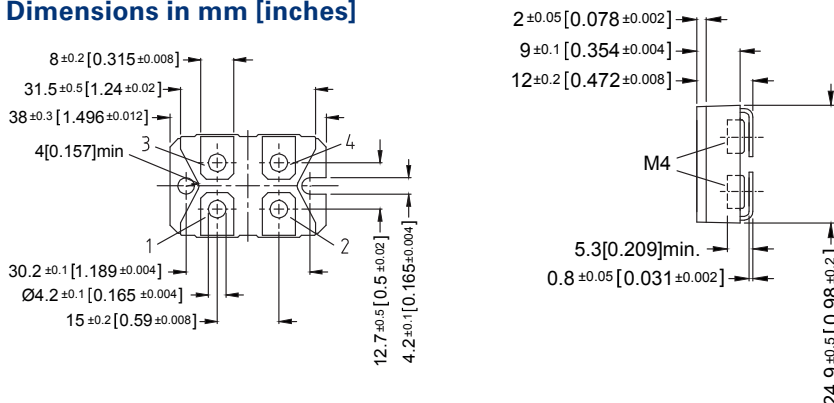

The above spec. sheet features our standard products. For further options please contact your local Miba Resistors representative.



# Series HXP 200, SOT-227



## Pulse Energy Curve (typical rating for HXP 200)

Note: These energy values are reference values → depending on ohmic value e.g. 1 Ω to 10 Ω and used resistive paste, a variation in max. energy load capability is possible

### Test procedure

Every test resistor was mounted with thermal compound (0.9 W/mK) on a water cooled heatsink

- Constant inlet water temperature: +50°C
- The test time of each tested resistor: 10min.
- Break time between two pulses: 1sec.
- To determine good / defect parts the ohmic value was measured before and after tests: a change of tolerance of more than 0.1% means defect

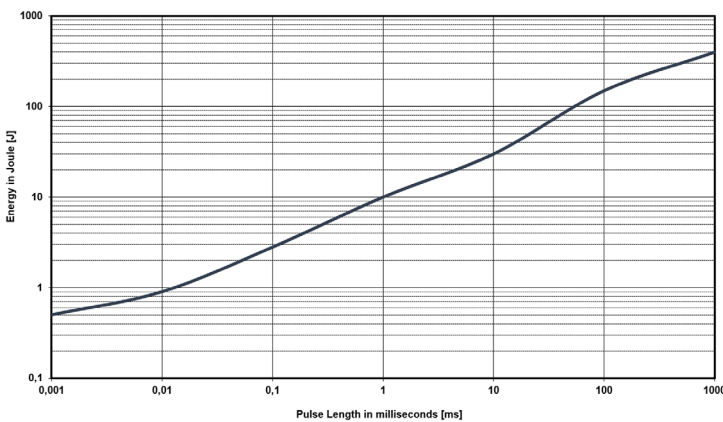

**Description of Pulse Energy Curve**

- Shape of pulse = e-function
- Time between two pulses = 1 second
- Pulse length = time constant of 1 tau (1 means ... tau = 1ms)

### Example

At 1 ms tau the HXP 200 with e.g. 1 Ω to 10 Ω can withstand an energy level of about 10 J, when the pulse pause time is ≥ 1s

**At a symmetrical frequency > 1 kHz at pulse length ≥ 10 μsec. the maximum applied pulse energy for HXP 200 is a result out of the nominal power 200 W divided by the operating frequency (at 85°C bottom case) (E = 200 W / F)**

## Pulse Power Curve (typical rating for HXP 200)

The power curve shows the max. possible power which can be applied for a certain duration. Referring to the same test procedure as described above.

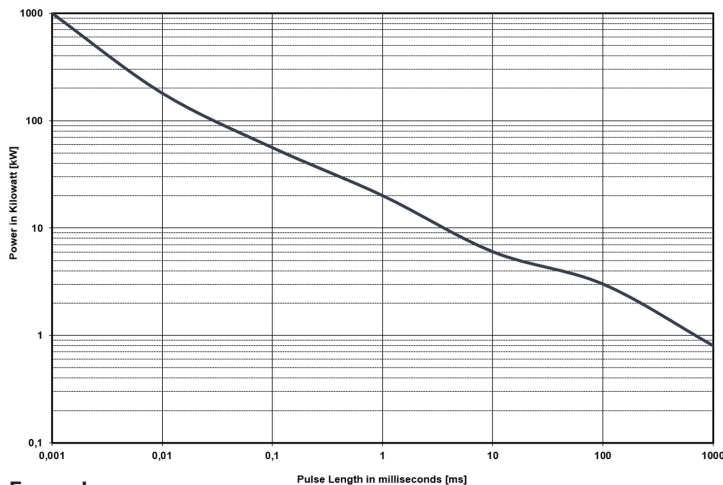

**Description of Pulse Power Curve**

- Shape of pulse = e-function
- Time between two pulses = 1 second
- Pulse length = time constant of 1 tau (1 means ... tau = 1ms)

### Example

For the time-constant of 1 ms you can apply about 20 kW max. ( $P_p = 2 \cdot E / T$ ) →, if the time between two such peaks is ≥ 1s



# Disclaimer

The given statements and information herein are recommendations for the use of our products and are based on our experience in combination with applicable technical standards.

They are for guidance only and do not represent any assurance of characteristics or warranty commitments for the products or their suitability for specific applications.

The suitability of the products for the intended use by the user depends on different boundary conditions and influencing factors and is to be assessed exclusively by the user.

**DISCLAIMER:**

NO WARRANTY OR GUARANTEE, EXPRESS OR IMPLIED, IS MADE WITH RESPECT TO THE PRODUCTS, DESIGNS, DATA, INFORMATION DESCRIBED OR ANY INTELLECTUAL PROPERTY CONTAINED THEREIN. ANY WARRANTY OR GUARANTEE OF MERCHANTABILITY OR FITNESS FOR A PARTICULAR PURPOSE IS ALSO EXCLUDED.

The given statements and information herein reflect the current status at the time of publication.

Typing or printing errors cannot be excluded.

This publication shall not be reprinted or reproduced in whole or in part in any form or by any means without the express written permission of Miba Resistors.