

Series HPP 150

150 W Power Resistor according to VDE 0160 und UL 94 V-0

A Miba Group Company

1/2

EBG Resistors's HPP series is rated at 150 W mounted to a heat sink. The increased height of the package makes the resistor ideal in applications where creeping distance must meet the VDE 0160 and UL 94 V-0 standards.

Features

- multiple resistors in 1 package
- Easy mounting using already existing infrastructure
- Non-Inductive design
- ROHS compliant
- Materials in accordance with UL 94 V-0 and VDE 0160

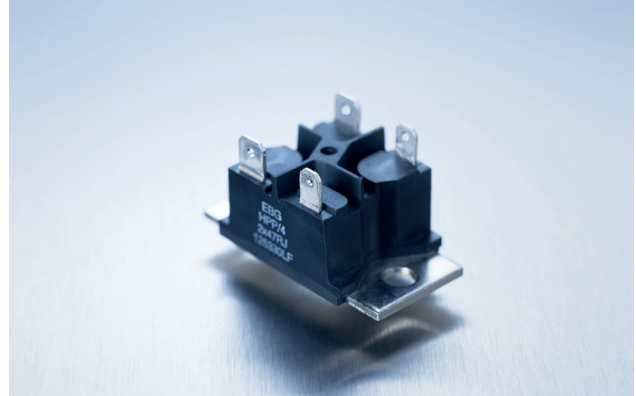

Technical Specifications

| | |
|--|--|
| Resistance value | 1 Ω ≤ 1 MΩ (other values on special request) |
| Resistance tolerance | ±1 % to ±10 % |
| Temperature coefficient | ±250 ppm/°C (at +85°C ref. to + 25°C) lower TCR on special request for limited ohmic values |
| Power rating | up to 150 W at 85°C bottom case temperature (see configurations) |
| Maximum working voltage | 500 V (up to 1,000 V DC on special request = "S"-version) |
| Voltage proof | 5,000 V DC, 3,000 V AC |
| Insulations resistance | 10 GΩ min. at 1 kV DC |
| Insolation voltage between R1 & R2 | 500 V (1,000 V on special request) |
| Comparative Tracking Index (CTI) | standard > 200 V (> 500 V on special request = "H"-version) |
| Heat resistance to cooling plate | Rth < 0.47 K/W |
| Capacitance/mass | 45 pF (typical), measuring frequency 10 kHz |
| Working temperatur range | -55°C to +155°C |
| Mounting - torque for base plate (static) | 1.3 Nm to 1.5 Nm M5 screws |
| Weight | ~38 g |

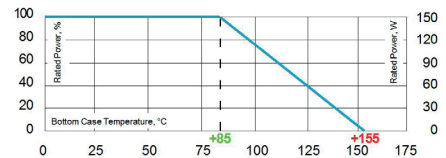

Derating (thermal resist.) HPP-150:
2.14 W/K (0.47 K/W) (for conf. 3)

Best results can be reached by using a thermal transfer compound with a heat conductivity of at least 1 W/mK. The flatness of the cooling plate must be better than 0.05 mm overall. Surface roughness should not exceed 6.4 μm.

How to make a request

HPP-Configuration_Ohmic Value_Tolerance

For example:

HPP-5 2x2R 10% or HPP-6 3x8K 5%

Example for higher working voltage:

HPP-4-S 2x10R 5%

Air distance contact to contact:

- | | | |
|---|--|--------------------|
| ③ | Contacts 1 and 2 resp. 3 and 4 - without fast-on-Plug: - with fast-on-Plug: | 9.2 mm 8.2 mm |
| ④ | Contacts 1 and 4 resp. 2 and 3 - without fast-on-Plug: - with fast-on-Plug: | 21.9 mm 20.9 mm |
| ⑤ | Contacts 2 resp. 3 and M5 - mounting screw with washer - without fast-on-Plug: - with fast-on-Plug: | 16.3 mm 15.9 mm |
| ⑥ | Contacts 1 resp. 4 and M5 - mounting screw with washer - without fast-on-Plug: - with fast-on-Plug: | 15.5 mm 15.0 mm |

Creeping distance:

- | | | |
|---|---|--------------------|
| ③ | Contacts 1 and 2 resp. 3 and 4 - without fast-on-Plug: - with fast-on-Plug: | 20.2 mm 19.0 mm |
| ④ | Contacts 1 and 4 resp. 2 and 3 - without fast-on-Plug: - with fast-on-Plug: | 27.4 mm 25.8 mm |
| ⑤ | Contacts 2 resp. 3 to base plate - without fast-on-Plug: - with fast-on-Plug: | 20.2 mm 19.8 mm |
| ⑥ | Contacts 1 resp. 4 to base plate - without fast-on-Plug: - with fast-on-Plug: | 19.5 mm 18.9 mm |

Dimensions in mm [inches]

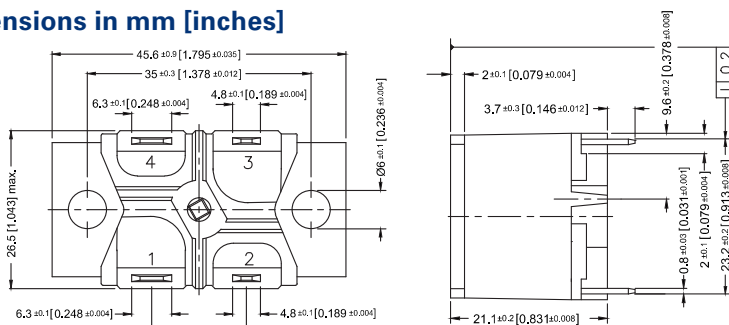

The above spec. sheet features our standard products. For further options please contact our local EBG representative or contact us directly.

Configurations (P / package)

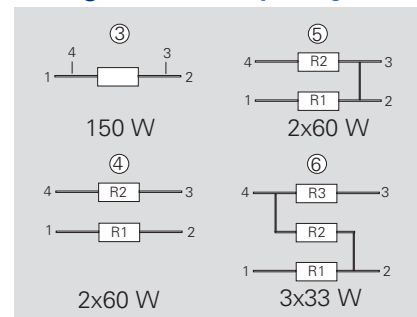

Version 5: ohmic value between contact 2 and 3 = 3mΩ

Series HPP 150



Pulse Energy Curve (typical rating for HPP 150)

Note: These energy values are reference values → depending on ohmic value e.g. 1 Ω to 10 Ω and used resistive paste, a variation in max. energy load capability is possible

Test procedure

Every test resistor was mounted with thermal compound (0.9 W/mK) on a water cooled heatsink

- Constant inlet water temperature: +50°C
- The test time of each tested resistor: 10min.
- Break time between two pulses: 1sec.
- To determine good / defect parts the ohmic value was measured before and after tests: a change of tolerance of more than 0.1% means defect

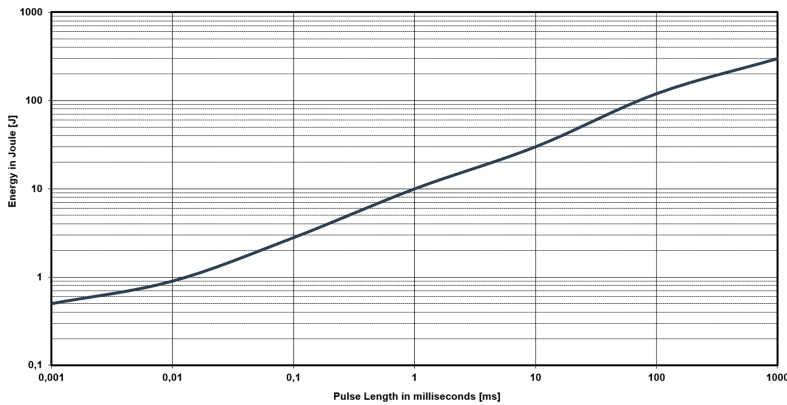

Description of Pulse Energy Curve

- Shape of pulse = e-function
- Time between two pulses = 1 second
- Pulse length = time constant of 1 tau (1 means ... tau = 1ms)

Example

At 1 ms tau the HPP 150 with e.g. 1 Ω to 10 Ω can withstand an energy level of about 10 J, when the pulse pause time is ≥ 1s

At a symmetrical frequency > 1 kHz at pulse length ≥ 10 μsec. the maximum applied pulse energy for HPP 150 is a result out of the nominal power 150 W divided by the operating frequency (at 85°C bottom case) (E = 150 W / F)

Pulse Power Curve (typical rating for HPP 150)

The power curve shows the max. possible power which can be applied for a certain duration. Referring to the same test procedure as described above.

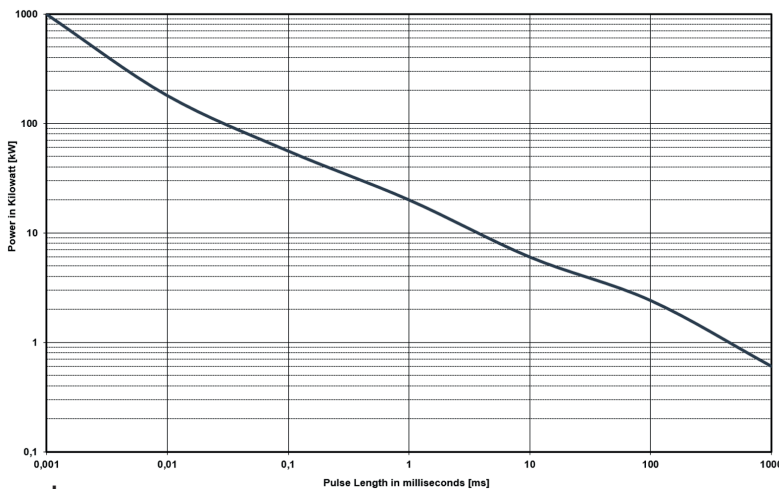

Description of Pulse Power Curve

- Shape of pulse = e-function
- Time between two pulses = 1 second
- Pulse length = time constant of 1 tau (1 means ... tau = 1ms)

Example

For the time-constant of 1 ms you can apply about 20 kW max. ($P_p = 2 \cdot E / T$) →, if the time between two such peaks is ≥ 1s